

Amana® Commercial

Project #: _____

Item #: _____



Low Volume Amana® Commercial Microwave RMS Series

Power Output

- 1000 watts of power
- Perfect replacement for inappropriate domestic ovens used in foodservice applications

Available with Touch or Dial Controls

- **Touch controls:**
 - 20 programmable menu items simplifies cooking
 - 5 power levels and 4 cooking stages for cooking flexibility
 - Multiple quantity pad calculates the proper cooking times for multiple portions
- **Dial Controls:**
 - Timer automatically resets to zero if door is opened during heating
 - 6 minute digital timer lights up for "at-a-glance" monitoring
 - Full power only for simple operation

Easy to Use

- See-through door and lighted interior for monitoring without opening the door
- 0.8 cubic foot (23 liter) capacity accommodates a 12" (305mm) platter, prepackaged foods and single servings

Certified Oven for Commercial Applications

- Tested to higher standards for a commercial rating —required by most commercial insurance policies and health inspectors
- Interlock safety switch is tested to 4 times the standard of residential ovens
- Constructed to withstand the foodservice environment, multiple users and variable ambient temperatures
- Compared to a residential oven, this oven is more powerful for faster heating and better quality results
- Engineered for a simple, "self-service" operation

Easy to Maintain

- Stainless steel exterior wrap, door, and oven interior for increased durability
- Sealed-in Borosilicate Glass shelf for easy cleaning

Value Line | Low Volume
This category of microwave oven is ideal for...

Applications

- Convenience Stores
- Coffee shops
- Dessert stations
- Teachers/Staff lounge
- Nurses stations
- Vending

Boost heats and re-therms foods in seconds

- Slice of apple pie re-therms in 20 seconds
- 9 oz. (255g) cup of chili re-therms in 1:45

All ACP, Inc. commercial ovens are supported by our Culinary Center. Do not hesitate to contact us for any questions regarding food preparation, menu development and cooking times: testkitchen@acpsolutions.com



Service

All products are backed by the ACP, Inc.
24/7 ComServ Support Center



Warranty

Warranty Certificate for this product can be found on the ACP, Inc. website at www.acpsolutions.com/warranty



Safety and Sanitation

This ACP, Inc. product meets and exceeds safety and sanitation standards set for commercial microwave ovens by UL, ETL, NSF, CSA, and FDA.



AIA File #:

Specification #:



© 2019 ACP, Inc.
Cedar Rapids, Iowa 52404

Amana® Commercial Microwave RMS Series | Low Volume

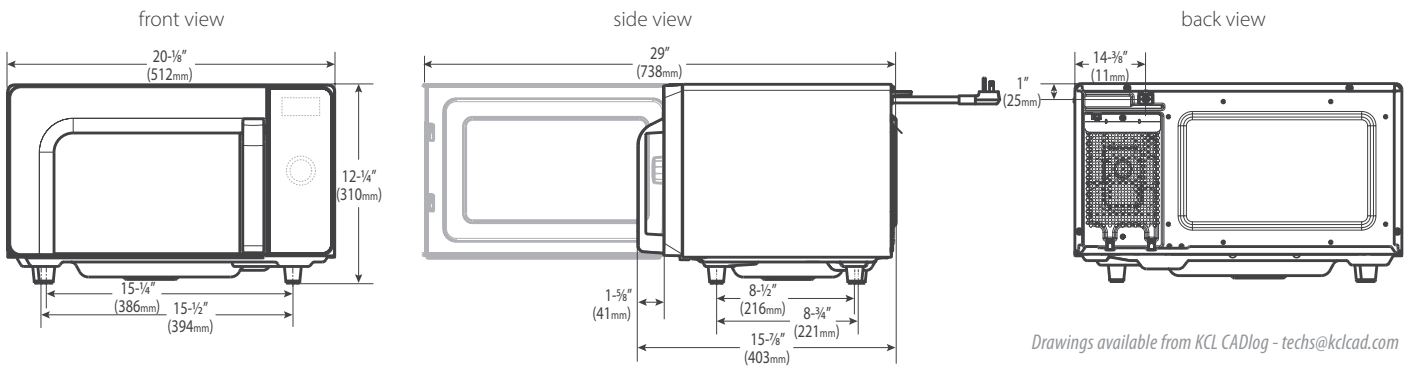

Dimensions

Exterior	H 12 1/4" (310)	W 20 1/8" (512)	D† 15 7/8" (403)
Cavity	H 7 3/4" (197)	W 13" (330)	D 13" (330)
Usable Cavity Space	0.8 cubic ft. (23 liter)		
Door Depth	29" (738), 90°+ door open		
Installation Clearances	Top: 7" (177.8)	Sides: 1" (25)	Back: None
Shipping Carton	H 15" (381)	W 23" (584)	D 18" (457)
Weight			
Product Weight	Ship weight (approx.)	UPS Shippable	
30 lbs. (13.6 kg.)	37 lbs. (16.8 kg.)	Yes	

Features

	Touch Models (TS)	Dial Models (DS)
Configuration	Countertop	Countertop
Stackable	No	No
Display	LED	Lighted Dial
Control System	Touchpad	Dial
Programmable Control	Yes, 10 pads	No
Braille	Overlay available	No
Settings Programmable	20	-
Max. Cooking Time	30:00	6:00
Microwave Distribution	Rotating stirrer, bottom	Rotating stirrer, bottom
Power Levels	5	1
Defrost	Yes, 20% power	No
Time Entry Option	Yes	Yes
Multiple Portion Setting	Yes, X2	No
Stage Cooking	4 stages	1 stage
Interior Light	Yes, LED, 42lm	Yes, LED, 42lm
Automatic Voltage Sensor	No	No
Air Filter	No	No
Signal	End of cycle, adjustable	End of cycle
Door Handle	Grab & Go	Grab & Go
Exterior Finish	Stainless steel	Stainless steel
Interior Finish	Stainless steel	Stainless steel

Optional Accessories

- Oven cavity shelf (SE10)
- Non-stick baskets (TB10/S, SB10/S, MB10/S)
- Stainless cart/equipment stands: (CA24, CA30)

Measurements are US Standard. Measurements in () are in millimeters

* IEC 60705 Tested

† Includes handle

Electrical Configuration

Region	Model#/UPC	Control System	Power Consumption	Power Output (microwave)	Power Source	Plug Configuration	Cord Length	Frequency	Magnetron
North America single phase	RMS10TSA 728028470208	Touch	1500 W, 13A	1000 W*	120 V, 60 Hz, 15 A, single phase	NEMA 5-15	5 ft. (1.5m)	2450MHz	1
North America single phase	RMS10DSA 728028470239	Dial	1500 W, 13A	1000 W*	120 V, 60 Hz, 15 A, single phase	NEMA 5-15	5 ft. (1.5m)	2450MHz	1



225 49th Ave. Dr. SW, Cedar Rapids, IA 52404 U.S.A.
800-233-2366 • 319-368-8120 • Fax: 319-368-8198
www.acpsolutions.com

Part No. 20271101

Updated 06/07/2019

© 2019 ACP, Inc., Cedar Rapids, Iowa 52404

an Ali Group Company



The Spirit of Excellence

Specification #:

AIA File #:



Left to right: HDC window door style and HDC solid door style (HDC18SD2)

Heavy Volume Amana® Commercial HDC Series

Power Output

- 1000-2100 Watts of power
- Unique method of microwave energy distribution provides superior even heating throughout the entire cavity

Multi-language universal operation, with programming flexibility

- Oven interface and programming software supports 24 languages
- Smart USB connectivity standard
- Compatible with ACP Programming Application

Easy to Use

- Up to 100 programmable menu items simplifies cooking
- 11 power levels and 4 cooking stages for cooking flexibility
- Multiple quantity function automatically calculates cooking times for multiple portions
- Automatic Voltage Sensor adjusts to the power supply (*North America only >1200W*)
- See-through door and lighted interior for monitoring without opening the door (*HDC18SD2 excluded*)
- Ample 0.6 cubic ft. (17 liter) capacity accommodates a standard half-sized pan
- Stackable to save valuable counter space

Easy to Maintain

- Stainless steel exterior and interior for easy cleaning and increased durability
- Removable, cleanable air filter protects oven components
- Constructed to withstand the foodservice environment, multiple users and variable ambient temperatures
- Gasket sealed Borosilicate Glass tray for easy cleaning
- Interlock switch assembly is engineered for maximum durability and long life.

Market Region: North America

Chef Line | Heavy Volume
This category of microwave oven is ideal for...

Applications

- Fast casual dining
- Prep stations
- Bars & grills
- Quick service restaurants
- Casual dining
- Convenience stores
- Bakery cafés
- Kiosks
- Food courts

Through put potential by oven wattage (items per hour)

Food item	1000W	1200W	1800W	2100W
Steamed Shrimp (8oz (227g))	22	23	33	38
Scrambled Eggs (4oz (120g))	48	51	65	72
Steamed Rice (8cups (1.2kg))	2	3	5	7
1 Baked potato (9oz (255g))	17	18	21	29
Salmon fillet (8oz (227g))	19	20	26	29
Chocolate Cake in a Cup	57	60	80	97
Fresh Steamed Veggies (6oz (170g))	45	48	65	80
Asparagus (8oz (227g))	29	30	45	51
Dumplings (6ea)	19	19	24	28

All ACP, Inc. commercial ovens are supported by our Culinary Center. Do not hesitate to contact us for any questions regarding food preparation, menu development and cooking times: testkitchen@acpsolutions.com



Optional Accessories

- Cavity shelf (SE10)
- Non-stick baskets (TB10/S, SB10/S, MB10/S)
- Oven Cleaner and Shield Protectant (CL10*, SH10*)

Service

All products are backed by the ACP, Inc.
24/7 ComServ Support Center

Warranty

Warranty Certificate for this product can be found on the ACP, Inc. website at www.acpsolutions.com/warranty

Safety and Sanitation

This ACP, Inc. product meets and exceeds safety and sanitation standards set for commercial microwave ovens by UL, ETL, NSF, CSA, and FDA.



For other market regions, please see product literature online

*Only shipped in U.S.A.



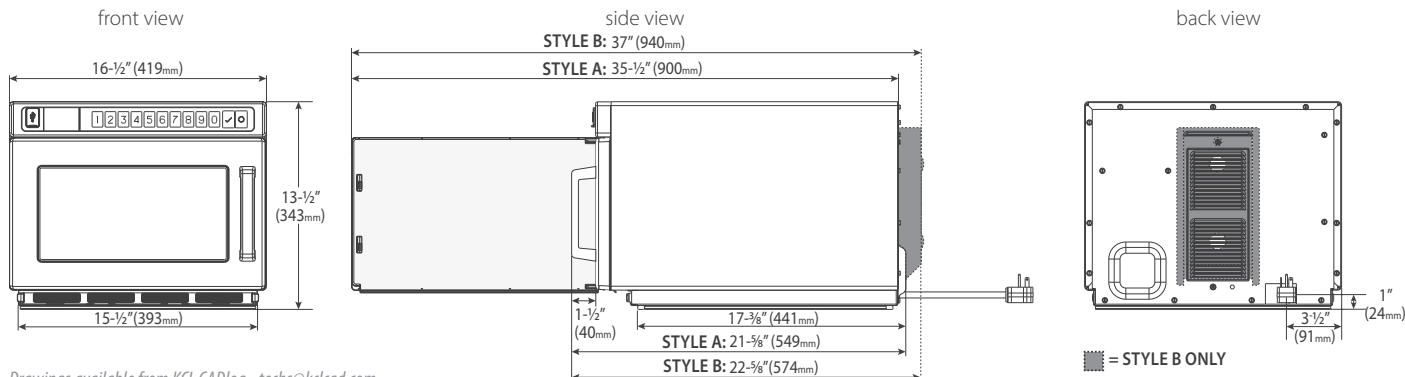

Drawings available from KCL CADlog - techs@kclcad.com

Dimensions		STYLE A	STYLE B
Exterior	Height	13 1/2" (343)	13 1/2" (343)
	Width	16 1/2" (419)	16 1/2" (419)
	Depth†	21 5/8" (549)†	22 5/8" (578)†
Cavity	Height	6 3/4" (171)	6 3/4" (171)
	Width	13" (330)	13" (330)
	Depth	12" (305)	12" (305)
Usable Cavity Space		0.6 cubic ft. (17 liter)	0.6 cubic ft. (17 liter)
Door Depth		35 1/2" (900), 90°+ door open	37" (940), 90°+ door open
Installation Clearance	Top	2" (51)	2" (51)
	Sides	1" (25)	1" (25)
	Back	None	None
Shipping Carton	Height	18 5/8" (473)	18 5/8" (473)
	Width	21 7/8" (556)	21 7/8" (556)
	Depth	24 5/8" (625)	24 5/8" (625)
Weight			
Product Weight	Ship weight (approx.)	UPS Shippable	
68 lbs (31kg)	74 lbs (34kg)	Yes, ISTA 1A	

Features	
Configuration	Countertop
Stackable	Yes
Display	LCD
Control System	Touchpad
Programmable Control	Yes, 10 pads
Braille	Overlay available
Settings Programmable	100
Max. Cooking Time	60:00
Microwave Distribution	Double rotating antennas, top and bottom
Power Levels	11
Defrost	Yes, power level 2
Time Entry Option	Yes
Multiple Portion Setting	Yes, X2 by default, optional up to X9
Stage Cooking	4 stages
Interior Light	Yes, LED
Automatic Voltage Sensor	Yes (North America only >1200W)
Air Filter	Yes, 1 removable
Signal	End of cycle, adjustable
Door Handle	Grab & Go
Exterior Finish	Stainless steel
Interior Finish	Stainless steel with gasket sealed borosilicate tray

Measurements are US Standard. Measurements in () are in millimeters

* IEC 60705 Tested

† Includes handle

Electrical Configuration

Region	Model#/ UPC	Automatic Voltage Sensor	Exterior Depth Style	Door Style	Power Consumption	Power Output (microwave)	Power Source	Plug Configuration	Cord Length	Frequency	Magnetron
North America single phase	HDC1015 728028470949	No	A	Window	1610W, 14.4 A	1000W*	120V, 60Hz, 15A, single phase	NEMA 5-15P	5 ft. (1.5m)	2450MHz	2
North America single phase	HDC12A2 719881159355	No	A	Window	2000W, 16.8 A	1200W*	120V, 60Hz, 20A, single phase	NEMA 5-20	5.5 ft. (1.7m)	2450MHz	2
North America single phase	HDC182 719881159362	Yes	A	Window	3000W, 14.4 A	1800W*	208/240V, 60Hz, 20A, single phase	NEMA 6-20	5.5 ft. (1.7m)	2450MHz	2
North America single phase	HDC1815 728028315929	Yes	A	Window	3000W, 14.4 A	1800W*	208/240V, 60Hz, 15A, single phase	NEMA L6-15P	5.5 ft. (1.7m)	2450MHz	2
North America single phase	HDC18SD2 719881159379	Yes	A	Solid	3000W, 14.4 A	1800W*	208/240V, 60Hz, 20A, single phase	NEMA 6-20	5.5 ft. (1.7m)	2450MHz	2
North America single phase	HDC212 719881159386	Yes	B	Window	3200W, 15.4 A	2100W*	208/240V, 60Hz, 20A, single phase	NEMA 6-20	5.5 ft. (1.7m)	2450MHz	2

Specification #:

AIA File #:



225 49th Ave. Dr. SW, Cedar Rapids, IA 52404 U.S.A.
800-233-2366 • 319-368-8120 • Fax: 319-368-8198
www.acpsolutions.com

Part No. 20271301

Updated 09/06/2022

© 2022 ACP, Inc., Cedar Rapids, Iowa 52404

an Ali Group Company



The Spirit of Excellence

Amana® Commercial

Project #: _____

Item #: _____



Model RCS10TS shown

Medium Volume

This category of microwave is ideal for...

Applications:

- Pizza restaurants
- Casual dining
- Clubs
- Deli

Defrost:

- Defrosts most frozen food products

All ACP, Inc. commercial ovens are backed by our Culinary Center. Call us with any question regarding food preparation, menu development and cooking times. 866-426-2621.



Medium Volume

Amana Commercial Microwave Model RCS10TS

Power Output

- 1000 watts of power.
- Five power levels for consistent, delicious results for frozen, refrigerated and fresh foods - from the freezer to table in minutes.

Easy to Use

- Up to 100 programmable menu items simplifies cooking and ensures consistent results.
- Four stage cooking option for easy one-touch cooking.
- Multiple quantity pad calculates the proper cooking times for multiple portions.
- User friendly touch controls are easy to use.
- Time entry option for added flexibility.
- Digital display with countdown timer for simple operation and "at-a-glance" monitoring.
- Braille touch pads are ADA compliant.
- See-through door and lighted interior for monitoring without opening the door.
- 1.2 cubic ft. (34 liter) capacity accommodates a 14" (356 mm) platter, prepackaged foods and single servings.
- Stackable to save valuable counter space.

Easy to Maintain

- Stainless steel exterior and interior for easy cleaning and a professional look.
- Non-removable air filter protects oven components.
- Constructed to withstand the foodservice environment.
- Backed by the ACP, Inc. 24/7 ComServ Support Center, 866-426-2621.
- ETL Listed.



Part No. 20154711
Updated 6/15/15
Original Instructions



© 2014 ACP, Inc.
Cedar Rapids, Iowa 52404

Amana Commercial Microwave Model RCS10TS | Medium Volume

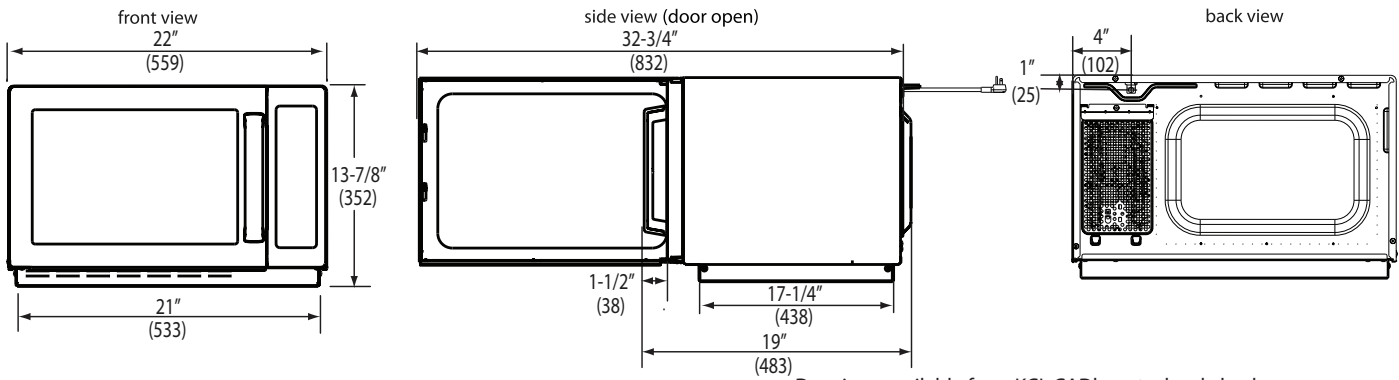

Installation clearance: 2" all sides

Drawings available from KCL CADlog - techs@kclcad.com

Specification #:

Specifications			
Model	RCS10TS	UPC Code 728028020724	
Configuration	Countertop		
Control System	Touch		
Programmable Control	10		
Settings Programmable	100		
Braille			
Max. Cooking Time	60:00		
Power Levels	5		
Defrost	Yes		
Time Entry Option	Yes		
Microwave Distribution	Rotating antenna, top		
Magnetron(s)	1		
Display	VFD		
Stackable	Yes		
Stage Cooking	Yes, 4		
Interior Light	Yes		
Door Handle	Grab & Go		
Signal	End of cycle, adjustable		
Air Filter	Non-removable with cleaning reminder		
Multiple Portion Setting	Yes, X2		
Exterior Dimensions	H 13 7/8" (352)	W 22" (559)	D*19" (483)
Cavity Dimensions	H 8 1/2" (216)	W 14 1/2" (368)	D 15" (381)
Door Depth	32 3/4" (832), 90°+ door open		
Usable Cavity Space	1.2 cubic ft. (34 liter)		
Exterior Finish	Stainless steel		
Interior Finish	Stainless steel		
Power Consumption	1550 W, 13 A		
Power Output**	1000 W** Microwave		
Power Source	120V, 60 Hz, 15 A single phase		
Plug Configuration / Cord	NEMA 5-15	5 ft. (1.5m)	
Frequency	2450 MHz		
Product Weight	41 lbs. (19 kg.)		
Ship weight (approx.)	47 lbs. (21 kg.)		
Shipping Carton Size	H 16 5/8" (422)	W 25 3/16" (640)	D 19 3/4" (502)
UPS Shippable	Yes		

Specifications

Commercial microwave 10 touch pad control panel shall be programmable with the ability to program up to 100 menu items with two multiple portions. Touch pad shall include Braille for ADA compliance. Cooking timer shall be 60 minute, countdown style with a time entry option and an adjustable end of cycle audible signal. There shall be 5 power levels, including defrost and 4 cooking stages. Microwave output shall be 1000 watts distributed by one magnetron with a rotating top antenna to provide superior even heating throughout the cavity. Durable door shall have a tempered glass window and a grab and go handle with a 90°+ opening for easy access. An interior light shall facilitate monitoring without opening the door. The large 1.2 cubic ft. (34 liter) cavity shall accommodate a 14" (356 mm) platter. Interior ceramic shelf shall be sealed and recessed on oven bottom to reduce plate-to-shelf edge impact. Oven shall have a stainless steel interior and exterior and be stackable to save counter and shelf space. Front air filter shall be permanently affixed to the front of the oven and have a clean filter reminder. Microwave oven shall comply with standards set by the U.S Department of Health and Human Services, UL923 for safety and NSF4 for sanitation.



Intertek



Intertek

Warranty

Warranty Certificate for this product can be found on the ACP, Inc. website at:

www.acpsolutions.com/warranty



Service

All products are backed by the ACP, Inc. 24/7 ComServ Support Center.

AIA File #:

Measurements in () are millimeters

* Includes handle

** IEC 60705 Tested

Part No. 20154711
Updated 6/15/15
Original Instructions



© 2014 ACP, Inc.
Cedar Rapids, Iowa 52404



Left to right: RC window door style and RC solid door style (*S2D)

Heavy Volume Amana® Commercial RC Series

Power Output

- 1700-3000 Watts of power
- Unique method of microwave energy distribution provides superior even heating throughout the entire cavity

Multi-language universal operation, with programming flexibility

- Oven interface and programming software supports 20 languages
- Smart USB connectivity standard
- Compatible with ACP Programming Application
- Stores up to 100 programmable menu items

Easy to Use

- 11 power levels and 4 cooking stages for cooking flexibility
- Multiple quantity function automatically calculates cooking times for multiple portions
- Automatic Voltage Sensor adjusts to the power supply
- See-through door and lighted interior for monitoring without opening the door (*S2D Models excluded)
- Ample 1 cubic ft. (28 liter) capacity accommodates two standard 4" (102mm) deep half-sized pans
- Stackable to save valuable counter space (*3000W models excluded)

Easy to Maintain

- Stainless steel exterior and interior for easy cleaning and increased durability
- Removable, cleanable air filter protects oven components
- Constructed to withstand the foodservice environment
- Interior borosilicate tray is sealed and recessed to reduce plate-to-shelf edge impact and keep spills contained

Chef Line | Heavy Volume This category of microwave oven is ideal for...

Applications

- Full service restaurants
- Prep stations
- Delis
- Quick service restaurants
- Casual dining
- Schools
- Healthcare
- Grocery Stores
- Food courts

Through put potential by oven wattage (items per hour)

Food item	1700W	2200W	3000W
Steamed Shrimp (1lb (454g))	31	36	48
Fresh Green Beans (12oz (340g))	36	42	55
1 Baked Potato (10oz (283g))	24	30	36
Salmon (6oz (170g))	27	31	33
Lobster Tail (4oz (114g))	23	25	31
Quinoa (1cup (150g))	5	5	6
Steamed Rice (8cups (1.2kg))	3	5	6
Berry Cobbler (7oz (200g))	65	80	120

All ACP, Inc. commercial ovens are supported by our Culinary Center. Do not hesitate to contact us for any questions regarding food preparation, menu development and cooking times:
testkitchen@acpsolutions.com



Optional Accessories

- Cavity shelf (SE10)
- Non-stick baskets (NB10/S, TB10/S, SB10/S, MB10/S)
- Oven Cleaner and Shield Protectant (CL10**, SH10**)

Service

All products are backed by the ACP, Inc.
24/7 ComServ Support Center

Warranty

Warranty Certificate for this product can be found on the ACP, Inc. website at www.acpsolutions.com/warranty

Safety and Sanitation

This ACP, Inc. product meets and exceeds safety and sanitation standards set for commercial microwave ovens by UL, ETL, NSF, CSA, and FDA



**Only shipped in U.S.A.



Amana® Commercial Microwave RC Series | Heavy Volume

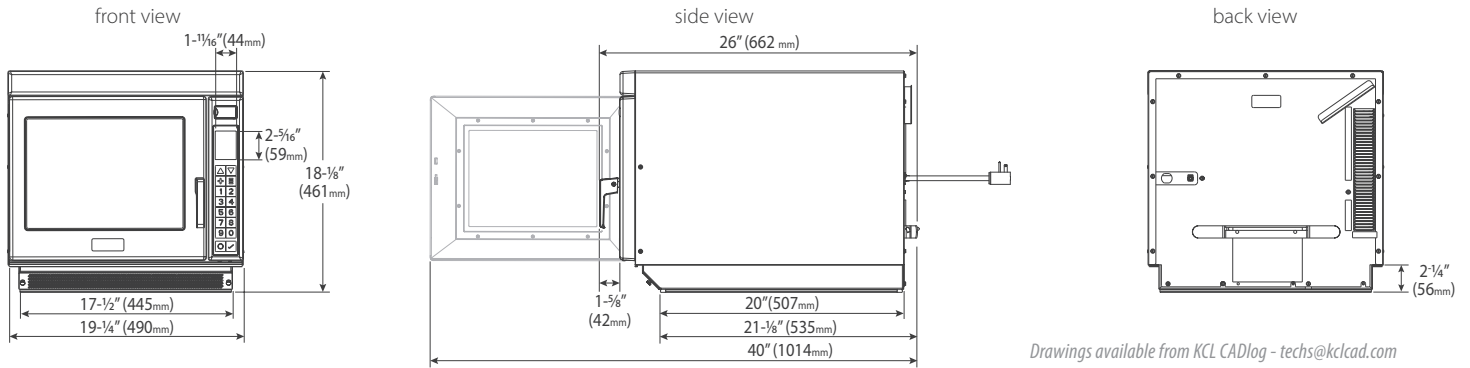

Drawings available from KCL CADlog - techs@kclcad.com

Dimensions			
Exterior	H 18 1/8" (461)	W 19 1/4" (490)	D† 26" (662)
Cavity	H 8 1/2" (216)	W 13" (330)	D 15" (381)
Usable Cavity Space	1.0 cubic ft. (28 liter)		
Door Depth	40" (1014), 90°+ door open		
Installation Clearance	Top: 2" (51)	Sides: 1" (25)	Back: None
Shipping Carton			
2 × Magnetron Models	H 21 1/2" (546)	W 21 3/4" (553)	D 28 1/4" (718)
3 × Magnetron Models	H 21 1/2" (546)	W 21 3/4" (553)	D 30" (762)
Weight			
Model Type	Product Weight	Ship weight (approx.)	
2 × Magnetron	94 lbs. (43 kg.)	101 lbs. (46 Kg.)	
3 × Magnetron	115 lbs. (52 kg.)	123 lbs. (56 Kg.)	

Features	
Configuration	Countertop
Display	2.8" (71mm) Color LCD
USB Port	Yes
Control System	Touchpad
Programmable Control	Yes, 10 pads
Braille	Overlay available
Settings Programmable	100
Max. Cooking Time	60:00
Microwave Distribution	2 × Magnetron Models: 2 rotating antennas-1 top; 1 bottom 3 × Magnetron Models: 3 rotating antennas-2 top; 1 bottom
Power Levels	11
Defrost	Yes, power level 2
Time Entry Option	Yes
Multiple Portion Setting	Yes, X2 by default, optional up to X9
Stage Cooking	4 stages
Interior Light	Window Door Style: Yes, LED Solid Door Style: No
Air Filter	Yes, 1 removable with cleaning reminder
Signal	End of cycle, adjustable
Door Handle	Lift & Pull
Exterior Finish	Stainless steel
Interior Finish	Stainless steel with sealed-in borosilicate tray

Measurements are US Standard. Measurements in () are in millimeters

* IEC 60705 Tested

† Includes handle

Electrical Configuration											
Region	Model#/UPC	Automatic Voltage Sensor	Door Style	Stackable	Power Consumption	Power Output (microwave)	Power Source	Plug Configuration	Cord Length	Frequency	Magnetron
North America single phase	RC17S2 719881159508	Yes	Window	Yes	2700W, 13.8A	1700W*	208/240V, 60Hz, 20A, single phase	NEMA 6-20P	5 ft. (1.5m)	2450MHz	2
North America single phase	RC17S2D 728028470635	Yes	Solid	Yes	2700W, 13.8A	1700W*	208/240V, 60Hz, 20A, single phase	NEMA 6-20P	5 ft. (1.5m)	2450MHz	2
North America single phase	RC22S2 042159061303	Yes	Window	Yes	3200W, 15.4A	2200W*	208/240V, 60Hz, 20A, single phase	NEMA 6-20P	5 ft. (1.5m)	2450MHz	2
North America single phase	RC22S2D 78028470642	Yes	Solid	Yes	3200W, 15.4A	2200W*	208/240V, 60Hz, 20A, single phase	NEMA 6-20P	5 ft. (1.5m)	2450MHz	2
North America single phase	RC30S2 719881159539	Yes	Window	No	4400W, 21.2A	3000W*	208/240V, 60Hz, 30A, single phase	NEMA 6-30P	5 ft. (1.5m)	2450MHz	3
North America single phase	RC30S2D 728028470659	Yes	Solid	No	4400W, 21.2A	3000W*	208/240V, 60Hz, 30A, single phase	NEMA 6-30P	5 ft. (1.5m)	2450MHz	3

ACP INC. 225 49th Ave. Dr. SW, Cedar Rapids, IA 52404 U.S.A.
800-233-2366 • 319-368-8120 • Fax: 319-368-8198
www.acpsolutions.com

Part No. 20271601

Updated 9/6/2022

© 2022 ACP, Inc., Cedar Rapids, Iowa 52404

an Ali Group Company



The Spirit of Excellence

Specification #:

AIA File #:

For future reference, please write the Model Number and Serial Number here.

Model Number _____

Serial Number _____

Commercial Microwave Oven Warranty

ACP warrants this product only when original purchaser uses the oven for commercial food service preparation.

Warranty

ACP, Inc. reserves the right, at its sole discretion, to repair or replace failed product covered by this warranty with new or factory recertified product of the same or similar model.

First Year

ACP will repair or replace any part (f.o.b. Cedar Rapids, Iowa, U.S.A.), that has failed due to workmanship or materials, including related labor and travel, except as provided in this warranty.

Second through Third Year

ACP will provide a replacement part, part only (f.o.b. Cedar Rapids, Iowa, U.S.A.), that has failed due to workmanship or materials. Owner will be responsible for paying all other costs including labor, mileage and transportation.

OWNER RESPONSIBILITIES:

- To obtain warranty service in the USA, you must contact ACP, Inc. ComServ Customer Service to request service at: Phone 866.426.2621 or email: commercialservice@acpsolutions.com. Outside the USA contact your local authorized distributor.
- Provide proof of purchase.
- Provide normal care and maintenance, including cleaning as instructed in owner's manual or product safety guide.
- Replace owner replaceable items where directions appear in the owner's manual.
- Make product accessible for service.
- Pay for premium service costs for service outside servicer's normal business hours and service area.
- Pay for service calls related to product installation and customer education.
- Pay for service calls and or freight charges for items not covered as listed below.

ITEMS NOT COVERED:

- Failures caused by:
 - Abuse or misuse.
 - Accident, fire, flood or acts of nature.
 - Any modification, alteration, adjustment or repair service not authorized by ACP.
 - Grease or other material buildup due to improper cleaning or maintenance.
 - Connection to an improper power supply.
 - Operating an empty oven.
 - Use of improper pans, containers, or accessories that cause damage to the product.
- Normal product maintenance and cleaning, including light bulbs.
- Lost or broken air filters or antenna shields.
- Replacement of oven liners.
- Damages which occur in shipment.
- Broken ceramic tray, stirrer covers.
- General rebuilding or refurbishing.

WARRANTY LIMITATIONS:

- Begins at date of original purchase.
- Applies to product used for NORMAL commercial food preparation.
- Service must be performed by an authorized ACP servicer.
- Replaced equipment warranty coverage will be for the remainder of the original equipment warranty.

WARRANTY IS VOID IF:

- Serial plate is defaced.
 - Product is altered by user.
 - Product is not installed or used according to manufacturer's instructions.
 - Product is installed in a prison or correctional facility.
- For answers to questions regarding the above, contact equipment supplier or:

ACP
Accelerated Cooking Products

ACP, Inc.
225 49th Avenue Drive SW
Cedar Rapids, Iowa 52404 U.S.A.
1-866-426-2621 (inside U.S.A. & Canada)
1-319-368-8120 (outside U.S.A. & Canada)

ANY IMPLIED WARRANTY OF MERCHANTABILITY AND/OR IMPLIED WARRANTY OF FITNESS FOR A PARTICULAR PURPOSE IS HEREBY EXCLUDED. IN NO EVENT SHALL ACP BE LIABLE FOR INCIDENTAL OR CONSEQUENTIAL DAMAGES.

Como fuente de consulta para el futuro, anote aquí el Número de modelo y el Número de serie.

Número de modelo _____

Número de serie _____

Garantía de Horno Microondas Comercial

ACP garantiza este producto sólo si el comprador original usa el horno para preparación de alimentos con fines comerciales.

Garantía

A su discreción única, ACP, Inc. se reserva el derecho de reparar o reemplazar un producto cubierto bajo esta garantía que haya fallado por un producto nuevo o reconstruido de un modelo igual o similar.

Primer año

ACP se compromete a reparar o reemplazar cualquier pieza, porte por cobrar, que haya fallado como consecuencia de la fabricación o los materiales, incluida la correspondiente mano de obra y transporte, con excepción de lo dispuesto en esta garantía.

Del segundo al tercer año

ACP se compromete a suministrar una pieza de reemplazo, porte por cobrar, que haya fallado como consecuencia de la fabricación o los materiales. Será responsabilidad del propietario el pago del resto de los gastos, entre ellos, mano de obra, kilometraje y transporte.

DEBERES DEL PROPIETARIO:

- Para obtener el servicio de garantía en EE.UU., deberá comunicarse con Apoyo al Servicio ComServ de ACP, Inc. para solicitar servicio al: teléfono 866.426.2621 o por correo electrónico: commercialservice@acpsolutions.com. Fuera de EE.UU, comuníquese con su distribuidor local autorizado.
- Proporcionar prueba de compra.
- Prestar el cuidado y mantenimiento normal, incluida la limpieza de acuerdo con las instrucciones del manual del propietario o la guía de seguridad del producto.
- Reemplazar los elementos reemplazables por el propietario para lo cual se incluyan las instrucciones en el manual del propietario.
- Permitir el acceso al producto para fines de reparación.
- Pagar un precio de reparación más elevado por concepto de servicios fuera del horario y zona de trabajo normales de la empresa de servicio técnico.
- Pagar llamadas de servicio técnico relacionadas con la instalación del producto y la formación del cliente.
- Pagar llamadas de servicio técnico y/o cargos de transporte por los elementos no amparados según se indica a continuación.

ELEMENTOS NO AMPARADOS:

- Fallos ocasionados por:
 - Abuso o mal uso.
 - Accidentes, incendio, inundación o casos fortuitos.
 - Toda modificación, alteración, ajuste o servicio de reparación no autorizados por ACP.
 - Acumulación de grasa u otras substancias debida a limpieza o mantenimiento incorrectos.
 - Conexión a una fuente de alimentación inadecuada.
 - Usar el horno estando vacío.
 - Uso de cacerolas, recipientes o accesorios inadecuados que dañen el producto.
- Mantenimiento y limpieza normal del producto, incluidas las bombillas eléctricas.
- Perdidos o rotos los filtros de aire o escudos de antena.
- Sustitución de revestimientos de horno.
- Daños ocurridos durante el envío.
- Ruptura de repisas de porcelana.
- Reconstrucción o modernización generales.

LIMITACIONES DE LA GARANTÍA:

- Empieza a partir de la fecha original de compra.
- Se aplica a productos utilizados para la preparación NORMAL de alimentos con fines comerciales.
- El servicio debe ser prestado por un servicio técnico ACP autorizado.
- La cubierta en garantía del equipo reemplazado estará avalada por el resto del periodo de garantía del equipo original.

LA GARANTÍA SE ANULA SI:

- Se borra el número de serie de la chapa correspondiente.
- El usuario modifica el producto.
- No se instala o utiliza el producto de acuerdo con las instrucciones del fabricante.
- El producto se instala en una prisión o institución correccional.

Si tiene preguntas acerca de la información suministrada, puede ponerse en contacto con el proveedor del equipo o con:



ACP, Inc.
225 49th Avenue Drive SW
Cedar Rapids, Iowa 52404 U.S.A.
1-866-426-2621 (en EE.UU. y Canadá)
1-319-368-8120 (fuera de EE.UU. y Canadá)

CUALQUIER GARANTÍA IMPLÍCITA DE COMERCIALIZACIÓN Y/O GARANTÍA IMPLÍCITA DE ADECUACIÓN PARA UN PROPÓSITO EN PARTICULAR QUEDA POR LA PRESENTE EXCLUIDA. BAJO NINGUNA CIRCUNSTANCIA SERÁ ACP RESPONSABLE DE DAÑOS INCIDENTALES O EMERGENTES.

Pour référence ultérieure, inscrire le numéro de modèle et de série ici.

Numéro de modèle _____

Numéro de série _____

Garantie pour four à micro-ondes commercial

ACP garantit ce produit seulement lorsque l'acheteur d'origine utilise le four dans la préparation commerciale d'aliments de restauration.

Garantie

ACP, Inc. se réserve le droit, à sa seule discrétion, de réparer ou de remplacer le produit défectueux couvert par la présente garantie par un nouveau produit ou un produit remis à neuf du même modèle ou d'un modèle similaire.

Première année

ACP réparera ou remplacera toute pièce, fret payable à destination, en cas de défaillance résultant de la qualité d'exécution ou des matériaux, y compris une défaillance associée à la main-d'œuvre et au transport, sauf stipulation de la présente garantie.

De la deuxième à la troisième année

ACP fournira une pièce de remplacement, fret payable à destination, en cas de défaillance résultant de la qualité d'exécution ou des matériaux. Le propriétaire devra assumer tous les autres frais, y compris les frais de main-d'œuvre, de kilométrage et de transport.

RESPONSABILITÉS DU PROPRIÉTAIRE :

- Pour bénéficier du service de garantie aux États-Unis, contacter le service clientèle d'ACP, Inc. ComServ pour demander ledit service, par téléphone au : 866.426.2621 ou par courriel à l'adresse : commercialservice@acpsolutions.com. À l'extérieur des États-Unis, contacter le distributeur local agréé.
- Fournir une preuve d'achat.
- Assurer une maintenance et un entretien réguliers, y compris un nettoyage conformément aux instructions du manuel de l'utilisateur ou du guide sur la sécurité des produits.
- Remplacer les articles remplaçables par le propriétaire, conformément aux directives du manuel de l'utilisateur.
- Rendre le produit accessible pour l'entretien.
- Payer des primes de service pour tout service fourni en dehors des heures ouvrées normales et à l'extérieur de la zone de service.
- Payer pour les appels de service associées à l'installation du produit et à la formation du client.
- Payer pour les appels de service et/ou les frais de transport pour les éléments non couverts listés ci-dessous :

ÉLÉMENTS NON COUVERTS :

- Défaillances causées par :
 - Abus ou mésusage.
 - Accident, incendie, inondation ou calamités naturelles.
 - Toute modification, toute altération, tout réglage ou toute réparation non autorisé(e) par ACP.
 - Accumulation de graisse ou d'autre matière résultant d'un nettoyage ou d'un entretien inadéquat.
 - Connexion à une source d'alimentation électrique inadéquate.
 - Fonctionnement du four à vide.
 - Utilisation de récipients, de conteneurs ou d'accessoires inadéquats qui endommagent le produit.
- Entretien et nettoyage normal du produit, y compris les ampoules.
- Filtres à air perdus ou brisés, bouclier antenne.
- Remplacement des revêtements de fours.
- Dommages survenus pendant l'expédition.
- Étagères en céramique brisées.
- Réfection ou remise à neuf générale.

LIMITATIONS DE GARANTIE :

- Commence à partir de la date d'achat d'origine.
- S'applique au produit pour la préparation commerciale NORMALE d'aliments.
- L'entretien doit être effectué par un préposé à l'entretien agréé par ACP.
- La couverture de la garantie pour l'équipement de remplacement s'étend pendant le reste de la durée de la garantie de l'équipement d'origine.

LA GARANTIE EST NULLE SI :

- La plaque du numéro de série est défigurée.
- Le produit est modifié par l'utilisateur.
- Le produit n'est pas installé ou utilisé conformément aux instructions du fabricant.
- Le produit est installé dans un établissement pénitentiaire ou correctionnel.

Pour obtenir toute information complémentaire portant sur les éléments ci-dessus, contacter le fournisseur de l'équipement ou :



Accelerated Cooking Products

ACP, Inc.

225 49th Avenue Drive SW

Cedar Rapids, Iowa 52404 U.S.A.

1-866-426-2621 (pour les États-Unis et le Canada)

1-319-368-8120 (en dehors des États-Unis et du Canada)

TOUTE GARANTIE IMPLICITE DE QUALITÉ MARCHANDE ET/OU TOUTE GARANTIE IMPLICITE D'ADÉQUATION À USAGE PARTICULIER EST EXCLUE PAR LA PRÉSENTE. EN AUCUN CAS ACP NE POURRA ÊTRE TENUE RESPONSABLE POUR DES DOMMAGES INDIRECTS OU CONSÉCUTIFS.

Notieren Sie die Modell- und Seriennummer für spätere Bezugnahme bitte hier.

Modellnummer _____

Seriennummer _____

Garantie für das gewerbliche Mikrowellengerät

ACP bietet nur dann Garantieleistungen für dieses Produkt, wenn der ursprüngliche Käufer das Gerät für die gewerbliche Essenszubereitung verwendet.

Garantie

ACP, Inc. behält sich das Recht vor, ein fehlerhaftes, unter dieser Garantie stehendes Produkt zu reparieren oder mit einem neuen bzw. generalüberholten Produkt desselben bzw. eines ähnlichen Modells zu ersetzen.

Erstes Jahr

ACP repariert oder ersetzt mit Ausnahme der in dieser Garantie aufgeführten Bedingungen jedes Teil, Unfrei Haus, einschließlich damit verbundener Arbeits- und Reisekosten, welches aufgrund von Verarbeitungs- oder Materialmängeln versagt.

Zweites und drittes Jahr

ACP ersetzt Teile, Unfrei Haus, die aufgrund von Verarbeitungs- und Materialmängeln versagt haben. Der Eigentümer des Geräts ist für alle anderen Kosten, einschließlich Arbeits- und Transportkosten sowie Kilometergeld, verantwortlich.

PFLICHTEN DES EIGENTÜMERS:

- Für Leistung im Gewährleistungsfall in den USA setzen Sie sich mit dem ComServ-Kundendienst von ACP, Inc. folgendermaßen in Verbindung: Telefonisch: 866.426.2621 oder E-Mail: commercialservice@acpsolutions.com. Außerhalb der USA setzen Sie sich mit Ihrem autorisierten Vertriebshändler vor Ort in Verbindung.
- Vorlage des Kaufnachweises.
- Vornahme normaler Pflege und Wartung. Dazu zählt die Reinigung nach den Anweisungen im Benutzer- oder Produktsicherheitshandbuch.
- Austausch von durch den Eigentümer austauschbaren Teilen gemäß den im Benutzerhandbuch angegebenen Anweisungen.
- Bereitstellung des Produkts für Wartungsarbeiten.
- Zahlung eines Aufschlags für Wartungsarbeiten, die außerhalb der normalen Öffnungszeiten und des normalen Wartungsbereichs vorgenommen werden.
- Zahlung für Wartungsarbeiten, die mit der Installation des Produkts und der Schulung des Kunden zusammenhängen.
- Zahlung für Wartungsarbeiten und/oder Frachtkosten für nachstehende, nicht von der Garantie abgedeckte Punkte.

NICHT VON DER GARANTIE ABGEDECKTE PUNKTE:

- Versagen aus folgenden Ursachen:
 - Missbrauch bzw. Fehlgebrauch.
 - Unfall, Brand, Überschwemmung und höhere Gewalt.
 - Alle Modifikationen, Änderungen, Anpassungen oder Reparaturen, die nicht von ACP genehmigt wurden.
 - Ansammlung von Fett oder anderen Stoffen aufgrund unsachgemäßer Reinigung bzw. Wartung.
 - Anschluss an eine ungeeignete Stromversorgung.
 - Betrieb eines leeren Geräts.
 - Gebrauch ungeeigneter Pfannen, Behälter oder Zubehörteile, die das Produkt beschädigen.
- Normale Wartung und Reinigung des Produktes, darunter Glühbirnen.
- Verlorene oder defekte Luftfilter oder Antenne abschirmt.
- Ersatz Backofenauskleidungen.
- Versandschäden.
- Zerbrochene Keramikabstellflächen.
- Allgemeine Überholungs- bzw. Instandsetzungsarbeiten.

GARANTIEEINSCHRÄNKUNGEN:

- Beginnen ab Datum des Originalkaufs.
- Gelten für Produkte, die für die NORMALE gewerbliche Essenszubereitung verwendet werden.
- Die Wartung muss von einem von ACP befugten Wartungstechniker vorgenommen werden.
- Die Garantie für ein ersetztes Gerät gilt für die restliche Zeit der ursprünglichen Gerätegarantie.

DIE GARANTIE ERLISCHT IN DEN FOLGENDEN FÄLLEN:

- Serienschild wurde unkenntlich gemacht.
- Vom Benutzer wurden Änderungen am Produkt vorgenommen.
- Das Produkt wurde nicht gemäß den Anweisungen des Herstellers installiert oder verwendet.
- Das Produkt wird in einer Justizvollzugsanstalt installiert.

Setzen Sie sich in Bezug auf Fragen zu den oben angeführten Punkten mit dem Lieferanten des Geräts in Verbindung oder wenden Sie sich an:



Accelerated Cooking Products

ACP, Inc.

225 49th Avenue Drive SW

Cedar Rapids, Iowa 52404 U.S.A.

1-866-426-2621 (von innerhalb der USA und Kanada)

1-319-368-8120 (von außerhalb der USA und Kanada)

JEGliche KONKLUDENTE GEWÄHRLEISTUNG DER TAUGLICHKEIT UND/ODER EIGNUNG FÜR EINEN BESTIMMTEN ZWECK IST HIERMIT AUSGESCHLOSSEN. IN KEINEM FALL HAFTET ACP FÜR BEGLEIT- ODER FOLGESCHÄDEN.

Teile-Nr. 20098404

Gedruckt 9/13

ACP Inc. • www.acpsolutions.com

© 2013 ACP, Inc.
Cedar Rapids, IA 52404